

## 0.45Ω Dual SPDT Bidirectional Analog Switch

Check for Samples: [TS3A5223](#)

### FEATURES

- **Low ON Resistance Switches**
  - 0.45 Ω (Typical) at 3.6V
  - 0.85 Ω (Typical) at 1.8V
- **Wide Supply Range: 1.65 V to 3.6 V**
- **1.0 V Compatible Logic Interface**
- **High Switch Bandwidth 80 MHz**
- **0.01% THD Across Entire Band**
- **Specified min Break-before-make**
- **Bi-directional Switching**
- **–75 dB Channel-to-Channel Cross Talk**
- **–70 dB Channel-to-Channel OFF Isolation of Very Low Power Dissipation and Leakage Currents**
- **Very Small QFN-10 Package: 1.8mm × 1.4mm**
- **ESD Protection on all Pins**
  - 2kV HBM, 500 V CDM

### APPLICATIONS

- **Portable Electronics**
- **Smartphones, Tablets**
- **Home Electronics**
- **Wireline Communication**

### DESCRIPTION

The TS3A5223 is a high-speed dual analog switch with break-before-make and bi-directional signal switching capability. The TS3A5223 can be used as a dual 2:1 multiplexer or a 1:2 dual de-multiplexer.

The TS3A5223 offers very low ON resistance, very low THD, channel-to-channel crosstalk and very high OFF isolation. These features make TS3A5223 suitable for application in Audio signal routing and switching applications.

The TS3A5223 control logic supports 1.0V-3.6V CMOS logic levels. The logic interface allows direct interface with a wide range of CPUs and microcontrollers without increasing the current drawn from supply (ICC) and thus lowering power consumption.

**Table 1. TS3A5223 Function Table**

SEL1	SEL2	COM1	COM2
0	0	NC1	NC2
1	1	NO1	NO2
1	0	NO1	NC2
0	1	NC1	NO2

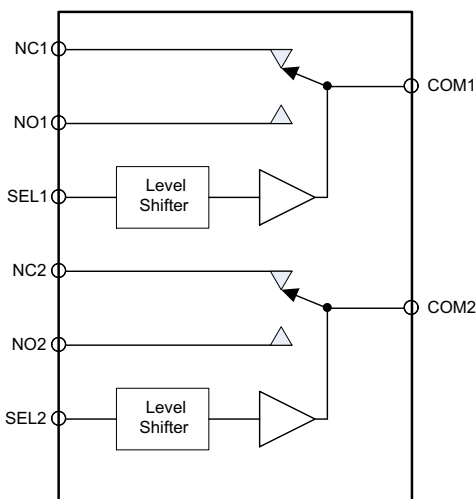
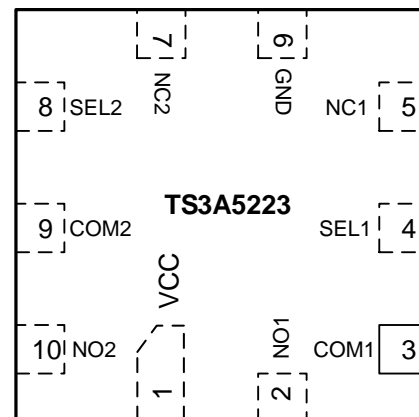
**TS3A5223 FUNCTIONAL DIAGRAM**

**Figure 1. Functional Diagram**
**TS3A5223 RSW (Top View)**

Please be aware that an important notice concerning availability, standard warranty, and use in critical applications of Texas Instruments semiconductor products and disclaimers thereto appears at the end of this data sheet.

# TS3A5223

SCDS339A – JANUARY 2013 – REVISED FEBRUARY 2013

[www.ti.com](http://www.ti.com)

## TS3A5223 PIN DESCRIPTION

NAME	PIN NUMBER	DESCRIPTION
VCC	1	Positive supply Input – Connect 1.65V up to 3.6V supply
NC1, NO1, NC2, NO2	5, 2, 7, 10	Channel Input/Output signal Pins
COM1, COM2	3, 9	Channel Input/Output signal Pins
GND	6	Ground reference pin
SEL1, SEL2	4, 8	Select logic pin

## ORDERING INFORMATION<sup>(1)</sup>

T <sub>A</sub>	PART NUMBER	PACKAGE		TOP-SIDE MARKING
–40°C to 85°C	TS3A5223RSWR	10-Pin $\mu$ -QFN	Reel of 3000	B2_

(1) For the most current package and ordering information, see the Package Option Addendum at the end of this document, or see the TI website at [www.ti.com](http://www.ti.com).

## ABSOLUTE MAXIMUM RATINGS<sup>(1)</sup>

Specified at T<sub>A</sub> = –40°C to 85°C unless otherwise noted.

		VALUE		UNIT
		MIN	MAX	
VCC	Positive DC Supply Voltage	–0.3	4.3 <sup>(2)</sup>	V
V <sub>IN-Max</sub>	Pins S1A, S1B, S2A, S2B, OUT1, OUT2, SEL1, SEL2 to GND pin voltage	–0.3	4.3 <sup>(2)</sup>	V
I <sub>OUT-Max</sub>	Pin OUT1, OUT2 max DC current		±300	mA
I <sub>OUT-Peak</sub>	Pin OUT1, OUT2 peak current (1ms pulse at 10% duty cycle)		±500	mA
P <sub>D</sub>	Total device power dissipation at T <sub>A</sub> = 85°C	10- $\mu$ QFN RSW	430	mW
ESD	ESD Rating – HBM		2000	V
	ESD Rating – CDM		500	V
T <sub>A</sub>	Operating free-air ambient temperature range	–40	85	°C
T <sub>J</sub>	Junction temperature range	–55	150	°C
T <sub>stg</sub>	Storage temperature range	–55	150	°C

- (1) Stresses beyond those listed under "Absolute Maximum Ratings" may cause permanent damage to the device. These are stress ratings only and functional operation of the device at these conditions is not implied. Exposure to absolute-maximum-rated conditions for extended periods may affect device reliability.
- (2) Not rated for continuous operation, 0.5% duty cycle at 1 kHz recommended

## DISSIPATION RATINGS<sup>(1)(2)(3)</sup>

BOARD	PACKAGE	$\theta_{JC}$	$\theta_{JA}$ <sup>(3)</sup>	DERATING FACTOR ABOVE T <sub>A</sub> = 25°C	T <sub>A</sub> < 25°C	T <sub>A</sub> = 70°C	T <sub>A</sub> = 85°C
High-K	10-Pin $\mu$ -QFN	46°C/W	93°C/W	10.7 mW/°C	1075W	590mW	430mW

- (1) Maximum dissipation values for retaining device junction temperature of 150°C
- (2) Refer to TI's design support web page at [www.ti.com/thermal](http://www.ti.com/thermal) for improving device thermal performance
- (3) Operating at the absolute T<sub>J-max</sub> of 150°C can affect reliability– for higher reliability it is recommended to ensure T<sub>J</sub> < 125°C

## RECOMMENDED OPERATING CONDITIONS

over operating free-air temperature range (unless otherwise noted)

		MIN	MAX	UNIT
VCC	Positive DC Supply Voltage	1.65	3.6	V
V <sub>Max</sub>	Pins NC1, NO1, NC2, NO2, COM1, COM2, SEL1, SEL2 to GND pin maximum voltage	0	3.6	V
T <sub>A</sub>	Operating free-air ambient temperature range	–40	85	°C
dt/dv	SEL pin Input rise and fall time limit	VCC = 1.6 to 2.7V		sec/V
		VCC = 3.0 to 3.6V		

## ELECTRICAL CHARACTERISTICS

Specified over the recommended junction temperature range  $T_A = T_J = -40^{\circ}\text{C}$  to  $85^{\circ}\text{C}$ . Typical values are at  $T_A = T_J = 25^{\circ}\text{C}$  (unless otherwise noted).

PARAMETER		VCC (V)	TEST CONDITIONS	MIN	TYP	MAX	UNIT
<b>DC CHARACTERISTICS</b>							
$V_{IH}$	High-level Input voltage SEL1, SEL2 inputs	3.6		0.8			V
		2.3		0.8			
		1.8		0.8			
$V_{IL}$	Low-level Input voltage SEL1, SEL2	3.6				0.3	V
		2.3				0.3	
		1.8				0.3	
$R_{ON}$	Switch ON Resistance	3.6	$V_S = 0$ to VCC, $I_S = 100$ mA, $V_{SEL} = 1.0\text{V}, 0\text{V}$		0.45	0.6	$\Omega$
		2.3			0.6	0.8	
		1.8			0.85	1.2	
$\Delta R_{ON}$	Difference of on-state resistance between switches	3.6	$V_S = 2\text{V}, 0.8\text{V}, I_S = 100$ mA, $V_{SE L} = 1.0\text{V}, 0\text{V}$		0.05		
$R_{ON-FLAT}$	ON resistance flatness	3.6	$V_S = 0$ to VCC, $I_S = 100\text{mA}$ , $V_{SEL} = 1.0\text{V}, 0\text{V}$		0.1	0.2	
		2.3			0.15	0.35	
		1.8			0.4	0.65	
$I_{OFF}$	NC, NO pin leakage current when not selected	3.6	$V_S = 0.3$ or $3.0\text{V}$ , $V_{COM} = 3.0$ or $0.3\text{V}$		5	90	nA
$I_{S(ON)}$	NC, NO pin leakage current when selected	3.6	$V_S = 0.3$ or $3.0\text{V}$ , $V_{COM} = \text{No Load}$		4	60	nA
$I_{SEL}$	Select Pin input leakage current	$V_S$	$V_S = 0$ or $3.6$ V			100	nA
$I_{CC}$	Quiescent supply current	3.6	$V_{SEL} = 0$ or VCC		700	2000	nA
$I_{CCLV}$	Supply current change	3.6	$V_{SEL} = 1.0\text{V}$ to $V_{SEL} = \text{VCC}$			200	nA
<b>SWITCHING PARAMETERS<sup>(1)(2)</sup></b>							
$t_{PHL}$	Logic high to low propagation delay	3.6	$R_L = 50 \Omega, C_L = 35$ pF		0.1		ns
		2.5			0.2		
		1.8			0.2		
$t_{PLH}$	Logic low to high propagation delay	3.6	$R_L = 50 \Omega, C_L = 35$ pF		0.1		ns
		2.5			0.2		
		1.8			0.2		
$t_{ON}$	Turn-ON time	2.3-3.6	$R_L = 50 \Omega, C_L = 35$ pF, $V_S = 1.5$ V			70	ns
$t_{OFF}$	Turn-OFF time	2.3-3.6	$R_L = 50 \Omega, C_L = 35$ pF, $V_S = 1.5$ V			75	ns
$t_D$	Break-before-make time delay	3.6	$R_L = 50 \Omega, C_L = 35$ pF, $V_S = 1.5$ V	2	8		ns
$Q_{INJ}$	Charge Injection	3.6	$C_L = 1$ nF, $V_S = 0$ V		40		pC
<b>AC CHARACTERISTICS</b>							
BW	-3dB Bandwidth	1.65V-3.6V	$R_L = 50 \Omega, C_L = 35$ pF		80		MHz
$V_{ISO}$	Channel OFF isolation	1.65V-3.6V	$V_S = 1$ V rms, $f = 100$ kHz		-70		dB
$V_{Xtalk}$	Channel-to-Channel Cross talk	1.65V-3.6V	$V_S = 1\text{V}$ rms, $f = 100\text{kHz}$		-75		dB
THD	Total harmonic distortion	1.65V-3.6V	$R_L = 600 \Omega, V_{SEL} = 2$ Vpk-pk, $f = 20$ Hz to $20$ kHz		0.01%		
$C_{SEL}$	Select Pin Input Capacitance	3.3V	$f = 1$ MHz		3		pF
$C_{ON}$	NC, NO, and COM input capacitance when switch is selected	3.3V	$f = 1$ MHz		115		pF
$C_{OFF}$	NC, NO, and COM input capacitance when switch is not selected	3.3V	$f = 1$ MHz		50		pF

- (1) Rise and Fall propagation delays,  $t_{PHL}$  and  $t_{PLH}$ , are measured between 50% values of the input and the corresponding output signal amplitude transition.
- (2) Assured by characterization only. Validated during qualification. Not measured in production testing.

TYPICAL CHARACTERISTICS

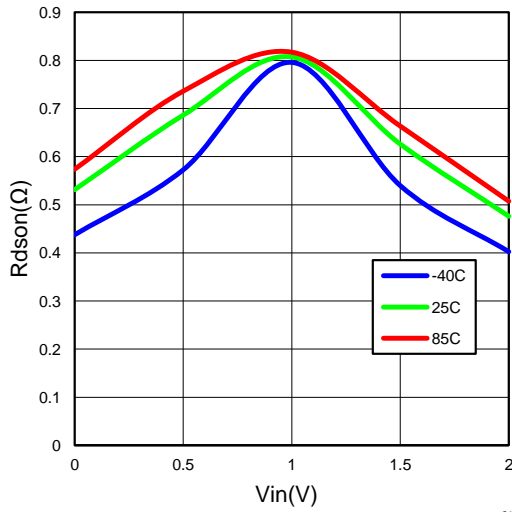

Figure 2. On-Resistance vs. Switch Input Voltage at VCC=1.8V

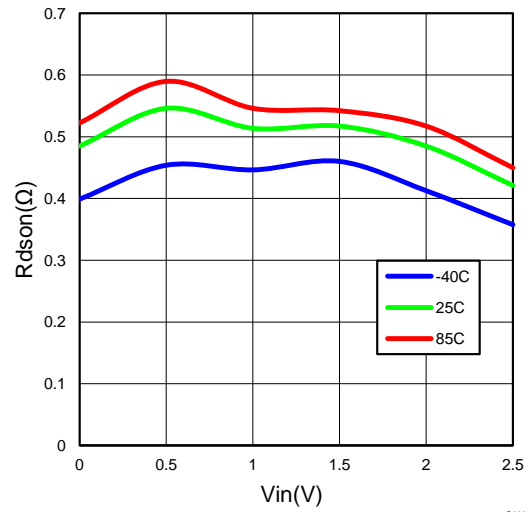

Figure 3. On-Resistance vs. Switch Input Voltage at VCC=2.3V

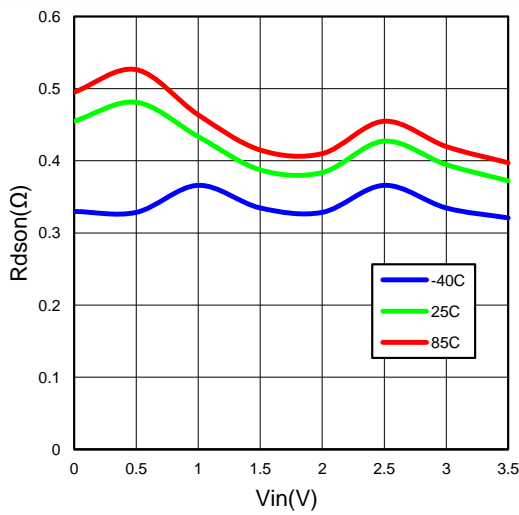

Figure 4. On-Resistance vs. Switch Input Voltage at VCC=3.0V

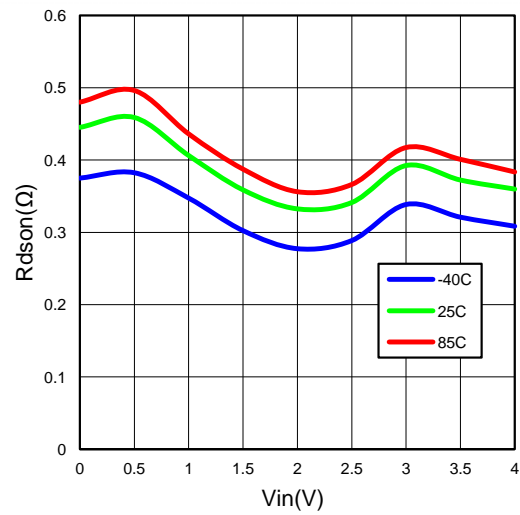

Figure 5. On-Resistance vs. Switch Input Voltage at VCC=3.6V

TYPICAL CHARACTERISTICS (continued)

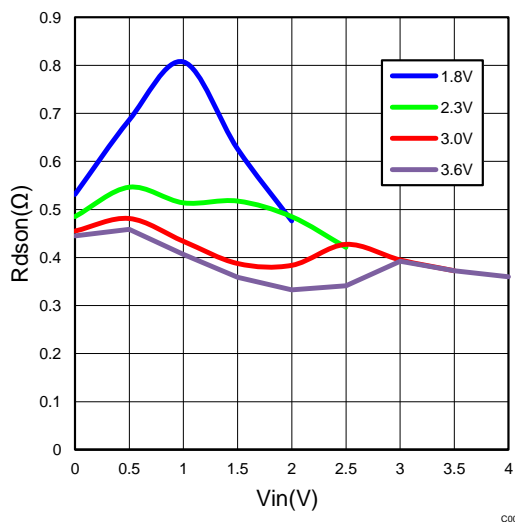

Figure 6. On-Resistance vs. Switch Input Voltage at  $T_A=25^{\circ}\text{C}$

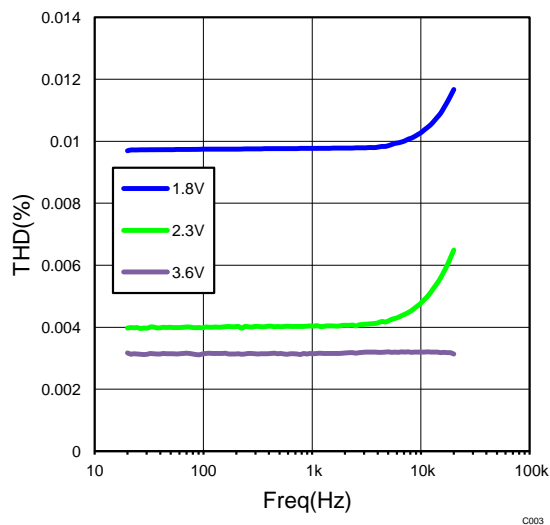
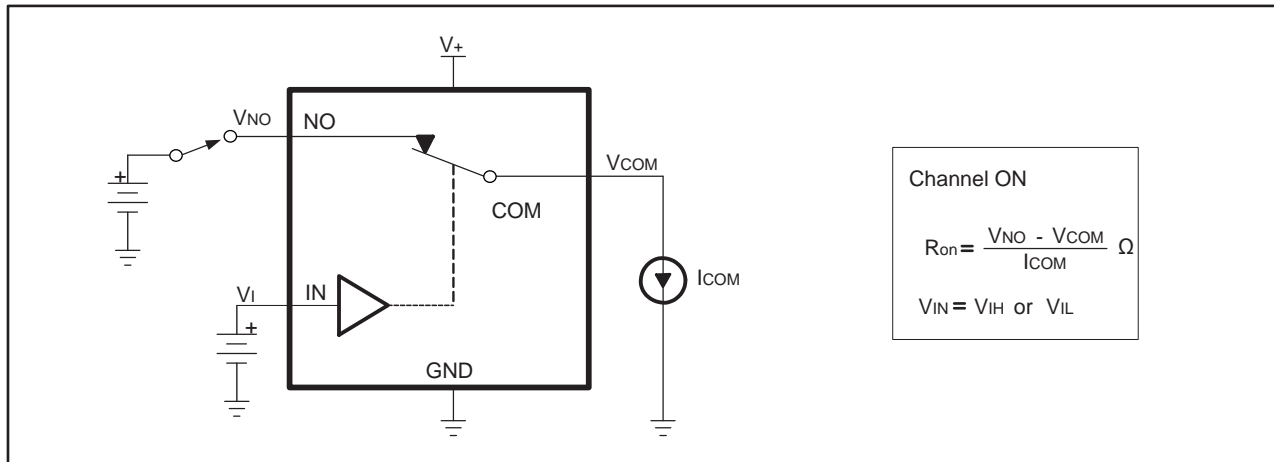
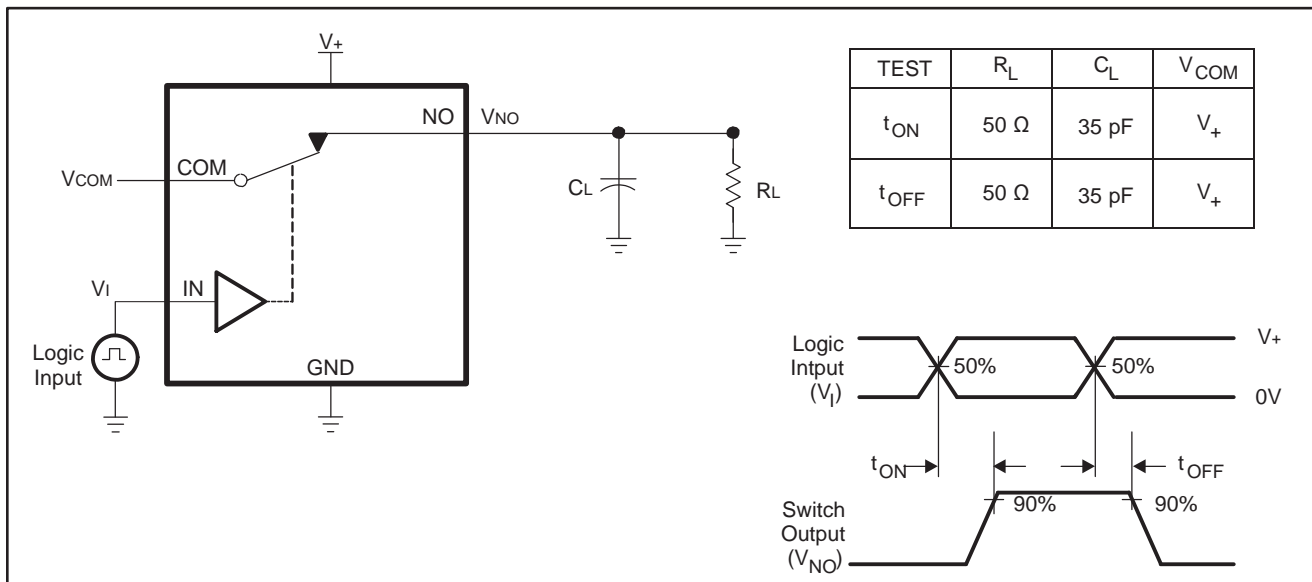

Figure 7. Total Harmonic Distortion

**PARAMETER MEASUREMENT INFORMATION**

**Figure 8. ON-State Resistance ( $R_{ON}$ )**

**Figure 9. Turn-On ( $t_{ON}$ ) and Turn-Off Time ( $t_{OFF}$ )**

PARAMETER MEASUREMENT INFORMATION (continued)

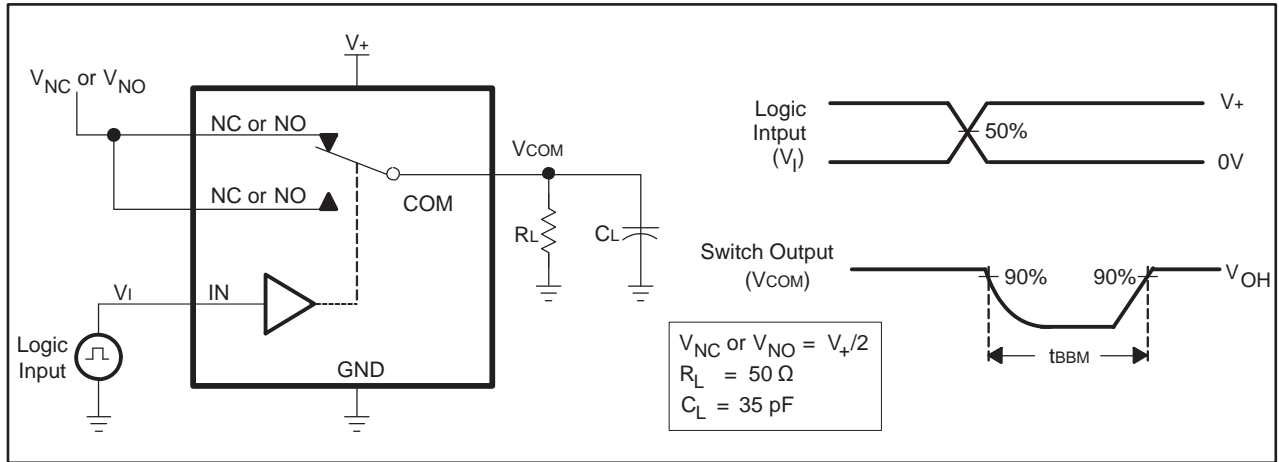

Figure 10. Break-Before-Make Time ( $t_D$ )

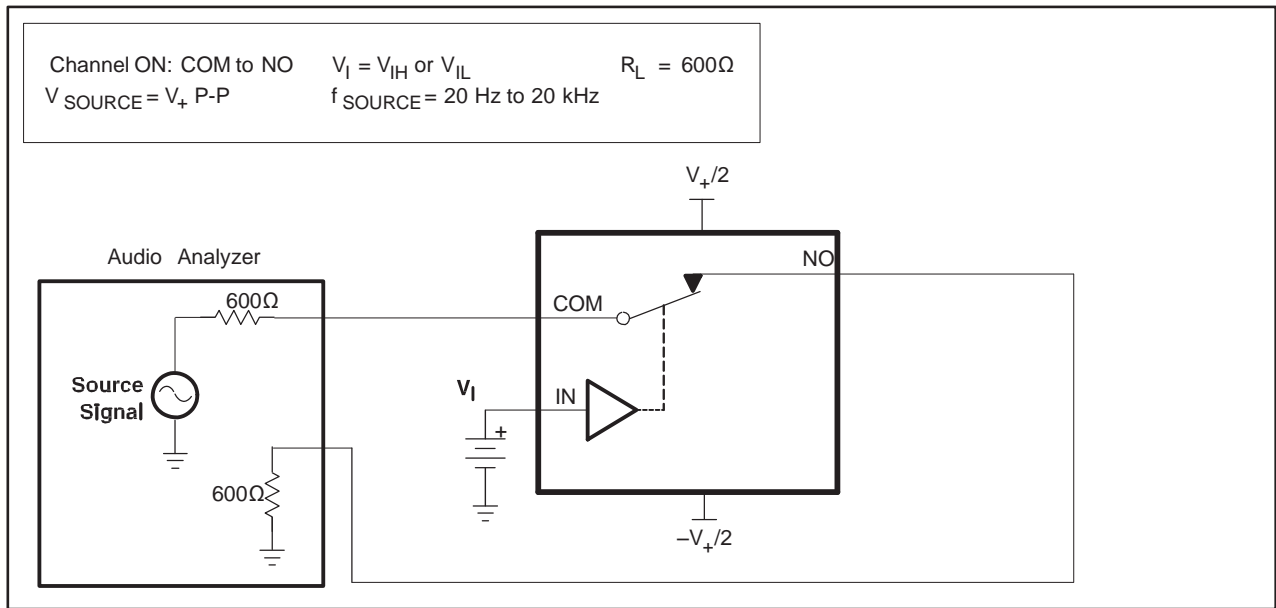

Figure 11. THIRD HARMONIC DISTORTION (THD)

PARAMETER MEASUREMENT INFORMATION (continued)

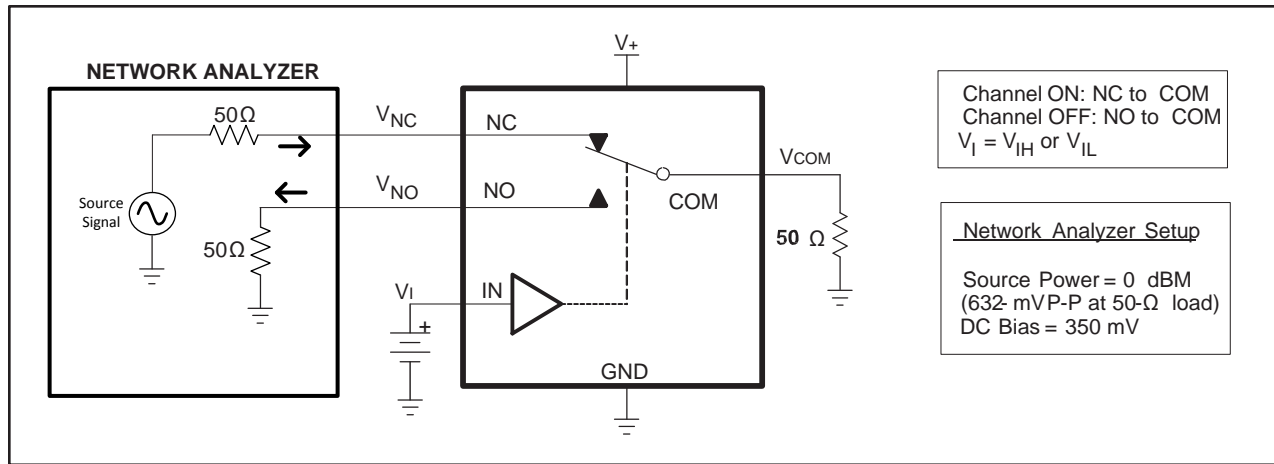

Figure 12. Crosstalk( $X_{TALK}$ )

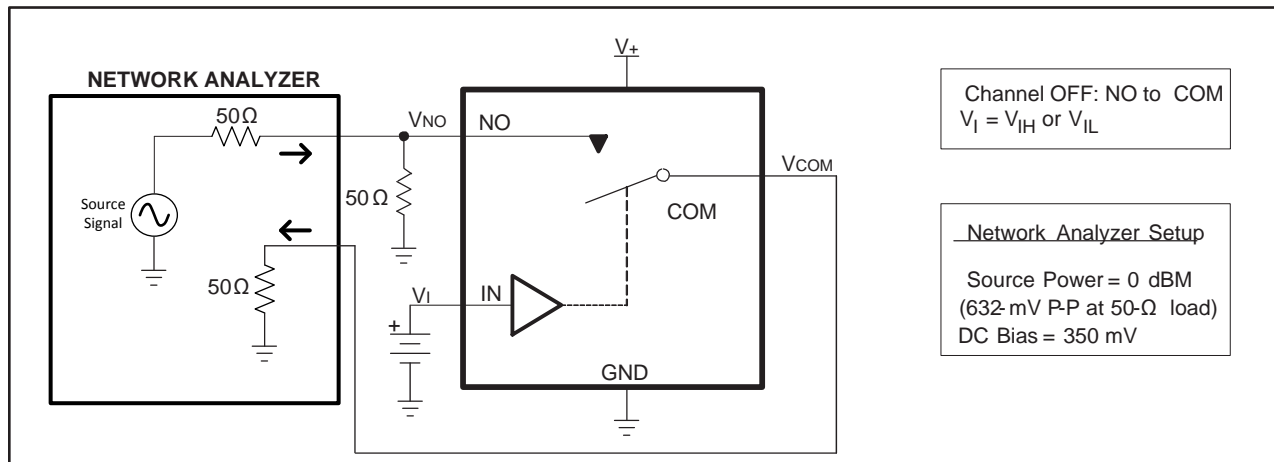

Figure 13. OFF Isolation ( $O_{ISO}$ )

**PACKAGING INFORMATION**

Orderable Device	Status (1)	Package Type	Package Drawing	Pins	Package Qty	Eco Plan (2)	Lead/Ball Finish	MSL Peak Temp (3)	Op Temp (°C)	Top-Side Markings (4)	Samples
TS3A5223RSWR	ACTIVE	UQFN	RSW	10	3000	Green (RoHS & no Sb/Br)	CU NIPDAU	Level-1-260C-UNLIM	-40 to 85	B2A	<a href="#">Samples</a>

(1) The marketing status values are defined as follows:

**ACTIVE:** Product device recommended for new designs.

**LIFEBUY:** TI has announced that the device will be discontinued, and a lifetime-buy period is in effect.

**NRND:** Not recommended for new designs. Device is in production to support existing customers, but TI does not recommend using this part in a new design.

**PREVIEW:** Device has been announced but is not in production. Samples may or may not be available.

**OBSOLETE:** TI has discontinued the production of the device.

(2) Eco Plan - The planned eco-friendly classification: Pb-Free (RoHS), Pb-Free (RoHS Exempt), or Green (RoHS & no Sb/Br) - please check <http://www.ti.com/productcontent> for the latest availability information and additional product content details.

**TBD:** The Pb-Free/Green conversion plan has not been defined.

**Pb-Free (RoHS):** TI's terms "Lead-Free" or "Pb-Free" mean semiconductor products that are compatible with the current RoHS requirements for all 6 substances, including the requirement that lead not exceed 0.1% by weight in homogeneous materials. Where designed to be soldered at high temperatures, TI Pb-Free products are suitable for use in specified lead-free processes.

**Pb-Free (RoHS Exempt):** This component has a RoHS exemption for either 1) lead-based flip-chip solder bumps used between the die and package, or 2) lead-based die adhesive used between the die and leadframe. The component is otherwise considered Pb-Free (RoHS compatible) as defined above.

**Green (RoHS & no Sb/Br):** TI defines "Green" to mean Pb-Free (RoHS compatible), and free of Bromine (Br) and Antimony (Sb) based flame retardants (Br or Sb do not exceed 0.1% by weight in homogeneous material)

(3) MSL, Peak Temp. -- The Moisture Sensitivity Level rating according to the JEDEC industry standard classifications, and peak solder temperature.

(4) Multiple Top-Side Markings will be inside parentheses. Only one Top-Side Marking contained in parentheses and separated by a "~" will appear on a device. If a line is indented then it is a continuation of the previous line and the two combined represent the entire Top-Side Marking for that device.

**Important Information and Disclaimer:**The information provided on this page represents TI's knowledge and belief as of the date that it is provided. TI bases its knowledge and belief on information provided by third parties, and makes no representation or warranty as to the accuracy of such information. Efforts are underway to better integrate information from third parties. TI has taken and continues to take reasonable steps to provide representative and accurate information but may not have conducted destructive testing or chemical analysis on incoming materials and chemicals. TI and TI suppliers consider certain information to be proprietary, and thus CAS numbers and other limited information may not be available for release.

In no event shall TI's liability arising out of such information exceed the total purchase price of the TI part(s) at issue in this document sold by TI to Customer on an annual basis.

## TAPE AND REEL INFORMATION



### QUADRANT ASSIGNMENTS FOR PIN 1 ORIENTATION IN TAPE



\*All dimensions are nominal

Device	Package Type	Package Drawing	Pins	SPQ	Reel Diameter (mm)	Reel Width W1 (mm)	A0 (mm)	B0 (mm)	K0 (mm)	P1 (mm)	W (mm)	Pin1 Quadrant
TS3A5223RSWR	UQFN	RSW	10	3000	180.0	9.5	1.16	1.16	0.5	4.0	8.0	Q1

**TAPE AND REEL BOX DIMENSIONS**



\*All dimensions are nominal

Device	Package Type	Package Drawing	Pins	SPQ	Length (mm)	Width (mm)	Height (mm)
TS3A5223RSWR	UQFN	RSW	10	3000	184.0	184.0	19.0

RSW (R-PUQFN-N10)

PLASTIC QUAD FLATPACK NO-LEAD

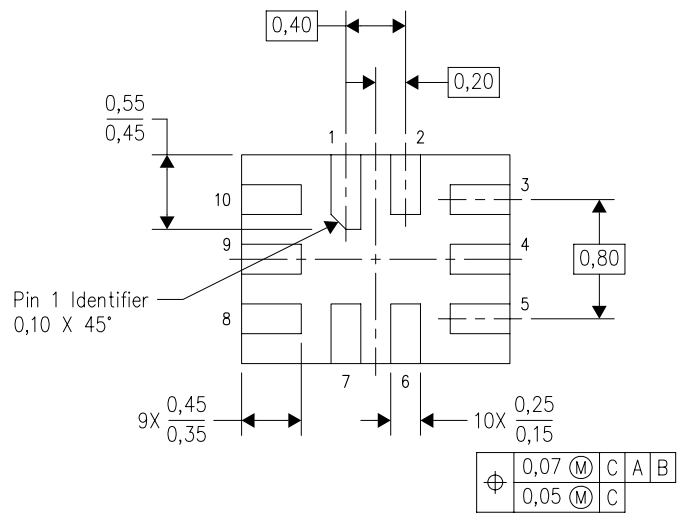
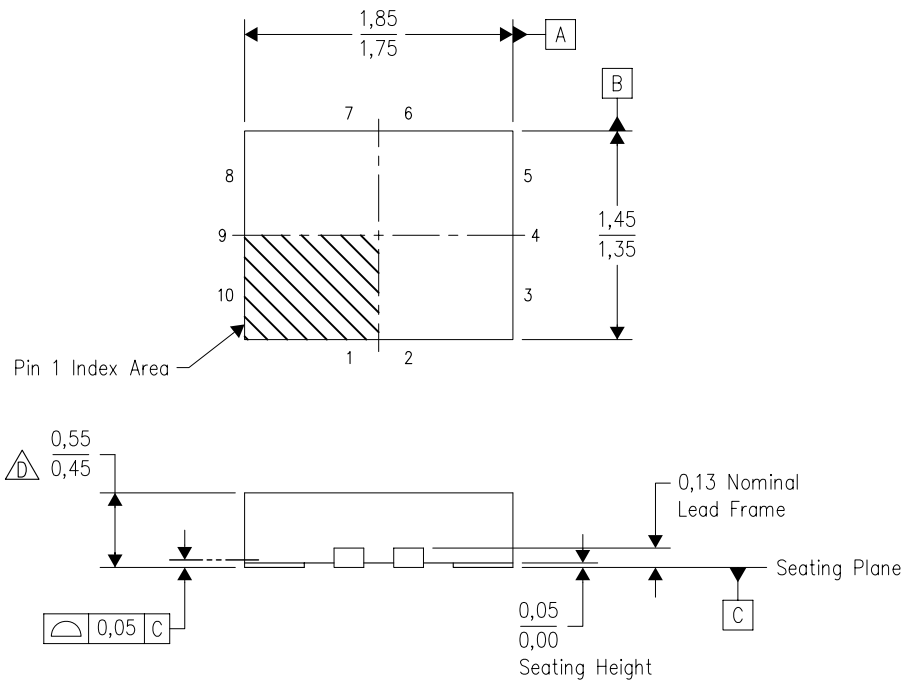

Bottom View

4208097/C 07/2008

- NOTES:
- A. All linear dimensions are in millimeters. Dimensioning and tolerancing per ASME Y14.5M-1994.
  - B. This drawing is subject to change without notice.
  - C. QFN (Quad Flatpack No-lead) package configuration.
  -  This package complies to JEDEC MO-288 variation UDEE, except minimum package height.



## IMPORTANT NOTICE

Texas Instruments Incorporated and its subsidiaries (TI) reserve the right to make corrections, enhancements, improvements and other changes to its semiconductor products and services per JESD46, latest issue, and to discontinue any product or service per JESD48, latest issue. Buyers should obtain the latest relevant information before placing orders and should verify that such information is current and complete. All semiconductor products (also referred to herein as "components") are sold subject to TI's terms and conditions of sale supplied at the time of order acknowledgment.

TI warrants performance of its components to the specifications applicable at the time of sale, in accordance with the warranty in TI's terms and conditions of sale of semiconductor products. Testing and other quality control techniques are used to the extent TI deems necessary to support this warranty. Except where mandated by applicable law, testing of all parameters of each component is not necessarily performed.

TI assumes no liability for applications assistance or the design of Buyers' products. Buyers are responsible for their products and applications using TI components. To minimize the risks associated with Buyers' products and applications, Buyers should provide adequate design and operating safeguards.

TI does not warrant or represent that any license, either express or implied, is granted under any patent right, copyright, mask work right, or other intellectual property right relating to any combination, machine, or process in which TI components or services are used. Information published by TI regarding third-party products or services does not constitute a license to use such products or services or a warranty or endorsement thereof. Use of such information may require a license from a third party under the patents or other intellectual property of the third party, or a license from TI under the patents or other intellectual property of TI.

Reproduction of significant portions of TI information in TI data books or data sheets is permissible only if reproduction is without alteration and is accompanied by all associated warranties, conditions, limitations, and notices. TI is not responsible or liable for such altered documentation. Information of third parties may be subject to additional restrictions.

Resale of TI components or services with statements different from or beyond the parameters stated by TI for that component or service voids all express and any implied warranties for the associated TI component or service and is an unfair and deceptive business practice. TI is not responsible or liable for any such statements.

Buyer acknowledges and agrees that it is solely responsible for compliance with all legal, regulatory and safety-related requirements concerning its products, and any use of TI components in its applications, notwithstanding any applications-related information or support that may be provided by TI. Buyer represents and agrees that it has all the necessary expertise to create and implement safeguards which anticipate dangerous consequences of failures, monitor failures and their consequences, lessen the likelihood of failures that might cause harm and take appropriate remedial actions. Buyer will fully indemnify TI and its representatives against any damages arising out of the use of any TI components in safety-critical applications.

In some cases, TI components may be promoted specifically to facilitate safety-related applications. With such components, TI's goal is to help enable customers to design and create their own end-product solutions that meet applicable functional safety standards and requirements. Nonetheless, such components are subject to these terms.

No TI components are authorized for use in FDA Class III (or similar life-critical medical equipment) unless authorized officers of the parties have executed a special agreement specifically governing such use.

Only those TI components which TI has specifically designated as military grade or "enhanced plastic" are designed and intended for use in military/aerospace applications or environments. Buyer acknowledges and agrees that any military or aerospace use of TI components which have **not** been so designated is solely at the Buyer's risk, and that Buyer is solely responsible for compliance with all legal and regulatory requirements in connection with such use.

TI has specifically designated certain components as meeting ISO/TS16949 requirements, mainly for automotive use. In any case of use of non-designated products, TI will not be responsible for any failure to meet ISO/TS16949.

### Products

Audio	<a href="http://www.ti.com/audio">www.ti.com/audio</a>
Amplifiers	<a href="http://amplifier.ti.com">amplifier.ti.com</a>
Data Converters	<a href="http://dataconverter.ti.com">dataconverter.ti.com</a>
DLP® Products	<a href="http://www.dlp.com">www.dlp.com</a>
DSP	<a href="http://dsp.ti.com">dsp.ti.com</a>
Clocks and Timers	<a href="http://www.ti.com/clocks">www.ti.com/clocks</a>
Interface	<a href="http://interface.ti.com">interface.ti.com</a>
Logic	<a href="http://logic.ti.com">logic.ti.com</a>
Power Mgmt	<a href="http://power.ti.com">power.ti.com</a>
Microcontrollers	<a href="http://microcontroller.ti.com">microcontroller.ti.com</a>
RFID	<a href="http://www.ti-rfid.com">www.ti-rfid.com</a>
OMAP Applications Processors	<a href="http://www.ti.com/omap">www.ti.com/omap</a>
Wireless Connectivity	<a href="http://www.ti.com/wirelessconnectivity">www.ti.com/wirelessconnectivity</a>

### Applications

Automotive and Transportation	<a href="http://www.ti.com/automotive">www.ti.com/automotive</a>
Communications and Telecom	<a href="http://www.ti.com/communications">www.ti.com/communications</a>
Computers and Peripherals	<a href="http://www.ti.com/computers">www.ti.com/computers</a>
Consumer Electronics	<a href="http://www.ti.com/consumer-apps">www.ti.com/consumer-apps</a>
Energy and Lighting	<a href="http://www.ti.com/energy">www.ti.com/energy</a>
Industrial	<a href="http://www.ti.com/industrial">www.ti.com/industrial</a>
Medical	<a href="http://www.ti.com/medical">www.ti.com/medical</a>
Security	<a href="http://www.ti.com/security">www.ti.com/security</a>
Space, Avionics and Defense	<a href="http://www.ti.com/space-avionics-defense">www.ti.com/space-avionics-defense</a>
Video and Imaging	<a href="http://www.ti.com/video">www.ti.com/video</a>

### TI E2E Community

[e2e.ti.com](http://e2e.ti.com)